

SUN2000-33KTL-A Smart Energy Center



Smart

8 strings intelligent monitoring



Efficient

Max. efficiency 98.6%



Safe

Fuse free design



Reliable

Type II surge arresters for DC & AC

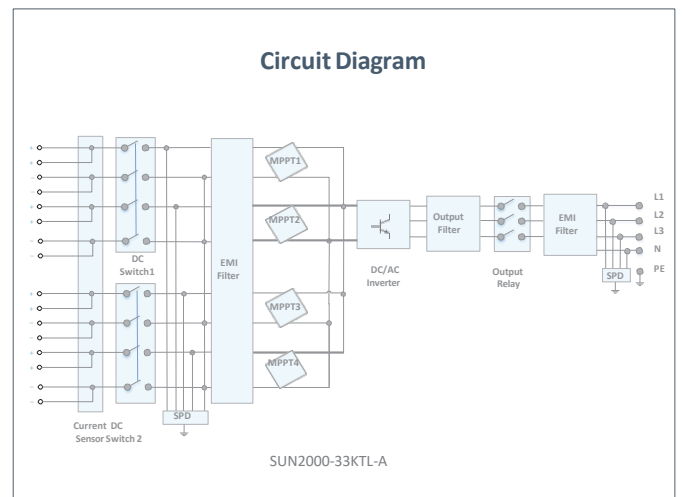
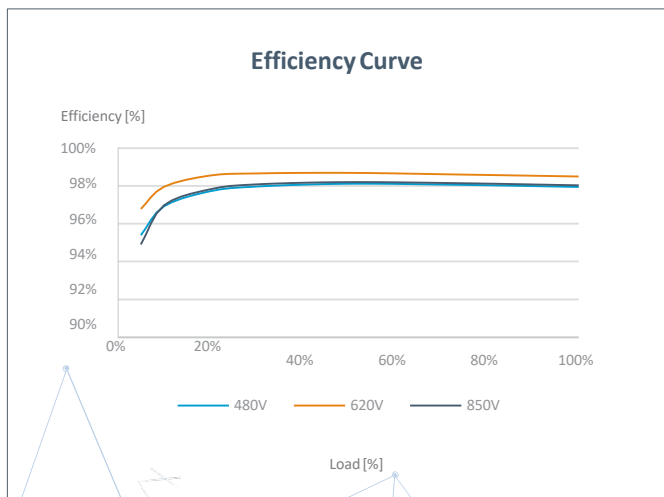

Technical Specification	SUN2000-33KTL-A
Efficiency	
Max. Efficiency	98.6%
European Efficiency	98.4%
Input	
Max. Input Voltage ¹	1,100 V
Max. Current per MPPT	22 A
Max. Short Circuit Current per MPPT	30 A
Start Voltage	250 V
MPPT Operating Voltage Range ²	200 V ~ 1,000 V
Rated Input Voltage	620 V
Number of MPP trackers	4
Max. input number per MPP tracker	2
Output	
Rated AC Active Power	30,000 W
Max. AC Apparent Power	33,000 VA
Max. AC Active Power	30,000 W
Rated Output Voltage	230 V / 400 V, 3W + N + PE;
Rated AC Grid Frequency	50 Hz / 60 Hz
Rated Output Current	43.3 A
Max. Output Current	48 A
Adjustable Power Factor Range	0.8 leading... 0.8 lagging
Max. Total Harmonic Distortion	<3%
Protection	
Input-side Disconnection Device	Yes
Anti-islanding Protection	Yes
AC Overcurrent Protection	Yes
DC Reverse-polarity Protection	Yes
PV-array String Fault Monitoring	Yes
DC Surge Arrester	Type II
AC Surge Arrester	Type II
DC Insulation Resistance Detection	Yes
Residual Current Monitoring Unit	Yes
Communication	
Display	LED indicators; WLAN adaptor + FusionSolar APP
RS485	Yes
USB	Yes
Monitoring BUS (MBUS)	Yes (isolation transformer required)
General Data	
Dimensions (W x H x D)	930 x 550 x 283 mm (36.6 x 21.7 x 11.1 inch)
Weight (with mounting plate)	62 kg (136.7 lb.)
Operating Temperature Range	-25 °C ~ 60 °C (-13°F ~ 140°F)
Cooling Method	Natural Convection
Max. Operating Altitude	4,000 m (13,123 ft.)
Relative Humidity	0 ~ 100%
DC Connector	Amphenol Helios H4
AC Connector	Waterproof PG Terminal + OT Connector
Protection Degree	IP65
Topology	Transformerless
Nighttime Power Consumption	< 2.5 W
Standard Compliance (more available upon request)	
Certificate	EN 62109-1/-2, IEC 62109-1/-2, IEC 62116
Grid Code	IEC 61727, VDE-AR-N-4105, VDE 0126-1-1, BDEW, G59/3, UTE C 15-712-1, CEI 0-16, CEI 0-21, RD 661, RD 1699, P.O. 12.3, RD 413, C10/11, EN 50438-Turkey, ABNT

*1 The maximum input voltage is the upper limit of the DC voltage. Any higher input DC voltage would probably damage inverter.

*2 Any DC input voltage beyond the operating voltage range may result in inverter improper operating.

