

SUN2000-36KTL Smart Energy Center



Smart

8 strings intelligent monitoring



Efficient

Max. efficiency 98.6%



Safe

Fuse free design



Reliable

Type II surge arresters for DC & AC

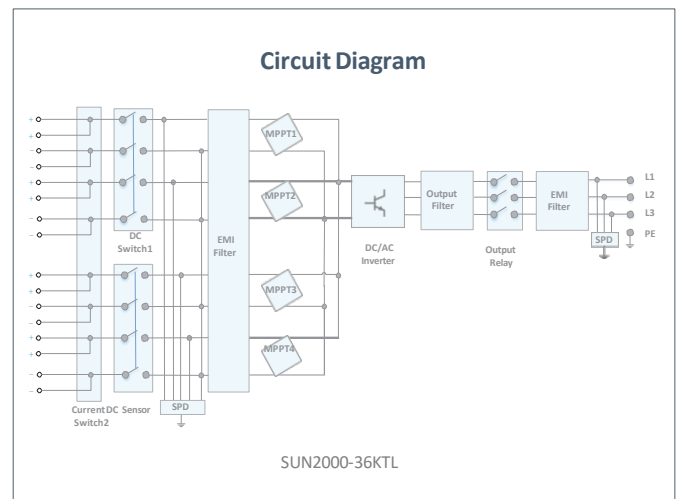
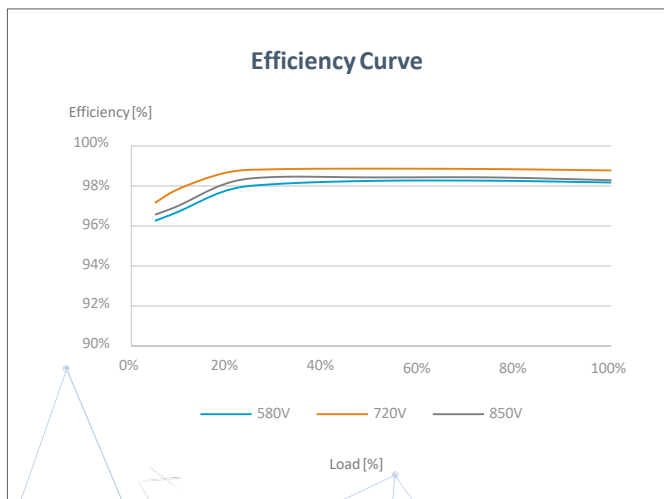

solar.huawei.com
inverter@huawei.com



photomate.eu
sales@photomate.eu

Technical Specification	SUN2000-36KTL
-------------------------	---------------

Efficiency	
Max. Efficiency	98.8% @480 V; 98.6% @380 V / 400 V
European Efficiency	98.6% @480 V; 98.4% @380 V / 400 V

Input	
Max. Input Voltage ¹	1,100 V
Max. Current per MPPT	22 A
Max. Short Circuit Current per MPPT	30 A
Start Voltage	250 V
MPPT Operating Voltage Range ²	200 V ~ 1,000 V
Rated Input Voltage	620 V @380 Vac / 400 Vac; 720 V @480 Vac
Number of MPP trackers	4
Max. input number per MPP tracker	2

Output	
Rated AC Active Power	36,000 W
Max. AC Apparent Power	40,000 VA ³
Max. AC Active Power (cosφ=1)	Default 40,000 W; 36,000 W optional in settings
Rated Output Voltage	220 V / 380 V, 230 V / 400 V, default 3W + N + PE; 3W + PE optional in settings 277 V / 480 V, 3W + PE
Rated AC Grid Frequency	50 Hz / 60 Hz
Rated Output Current	54.6 A @380 V, 52.2 A @400 V, 43.4 A @480 V
Max. Output Current	60.8 A @380 V, 57.8 A @400 V, 48.2 A @480 V
Adjustable Power Factor Range	0.8 leading... 0.8 lagging
Max. Total Harmonic Distortion	<3%

Protection	
Input-side Disconnection Device	Yes
Anti-islanding Protection	Yes
AC Overcurrent Protection	Yes
DC Reverse-polarity Protection	Yes
PV-array String Fault Monitoring	Yes
DC Surge Arrester	Type II
AC Surge Arrester	Type II
DC Insulation Resistance Detection	Yes
Residual Current Monitoring Unit	Yes

Communication	
Display	LED indicators; WLAN adaptor + FusionSolar APP
RS485	Yes
USB	Yes
Monitoring BUS (MBUS)	Yes (isolation transformer required)

General Data	
Dimensions (W x H x D)	930 x 550 x 283 mm (36.6 x 21.7 x 11.1 inch)
Weight (with mounting plate)	62 kg (136.7 lb.)
Operating Temperature Range	-25°C ~ 60°C (-13°F ~ 140°F)
Cooling Method	Natural Convection
Max. Operating Altitude	4,000 m (13,123 ft.)
Relative Humidity	0 ~ 100%
DC Connector	Amphenol Helios H4
AC Connector	Waterproof PG Terminal + OT Connector
Protection Degree	IP65
Topology	Transformerless
Nighttime Power Consumption	< 2.5 W

Standard Compliance (more available upon request)	
Certificate	EN 62109-1/-2, IEC 62109-1/-2, EN 50530, IEC 62116, IEC 60068, IEC 61683
Grid Code	IEC 61727, VDE-AR-N4105, VDE 0126-1-1, BDEW, G59/3, UTE C 15-712-1, CEI 0-16, CEI 0-21, RD 661, RD 1699, P.O. 12.3, RD 413, EN-50438-Turkey, EN-50438-Ireland, C10/11, MEA, Resolution No.7, NRS 097-2-1, AS/NZS 4777.2

^{*1} The maximum input voltage is the upper limit of the DC voltage. Any higher input DC voltage would probably damage inverter.

^{*2} Any DC input voltage beyond the operating voltage range may result in inverter improper operating.

^{*3} The maximum active power is determined by PQ mode setting. If PQ mode 1 is selected, the maximum active power equals the maximum apparent power. If PQ mode 2 is selected, the maximum active power equals the rated active power.

